

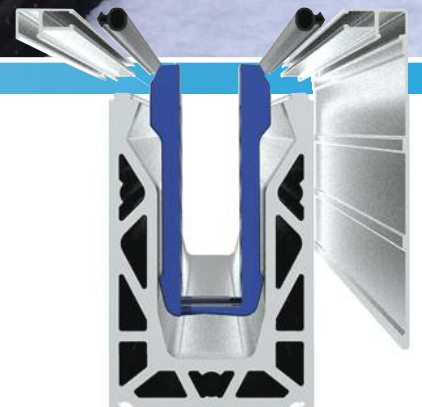

posiglaze

Frameless Glass Balustrade Solutions



# Posiglaze is our innovative aluminium railing system

## ■ FAST INSTALLATION

Designed to be installed without the need of ensuring the fitting surface is totally level.

## ■ FULLY ADJUSTABLE AFTER INSTALLATION

Posi Glaze uses a unique, simple adjustment system allowing horizontal alignment of each glass panel.

## ■ LIGHT WEIGHT AND EXTREMELY STRONG

Cleverly designed out of extruded aluminium, saving weight yet keeping strength. For added protection we anodise our system increasing protection against the elements.

## ■ EXCELLENTLY ENGINEERED

Our system is tested & engineered to meet the strictest building regulations (with the appropriate fixing and glass thickness) in both domestic and commercial installations. It can be installed in a wide variety of applications.

## ■ GLASS THICKNESSES

- 12mm (toughened glass) • 13.5mm (toughened laminate) • 15mm (toughened glass)
- 17.5mm (toughened laminate) • 19mm (toughened glass) • 21.5mm (toughened laminate)

NOTE: ALL GLASS CLAMPS HAVE A 1MM TOLERANCE TO ACCEPT VARYING INTERLAYER THICKNESSES

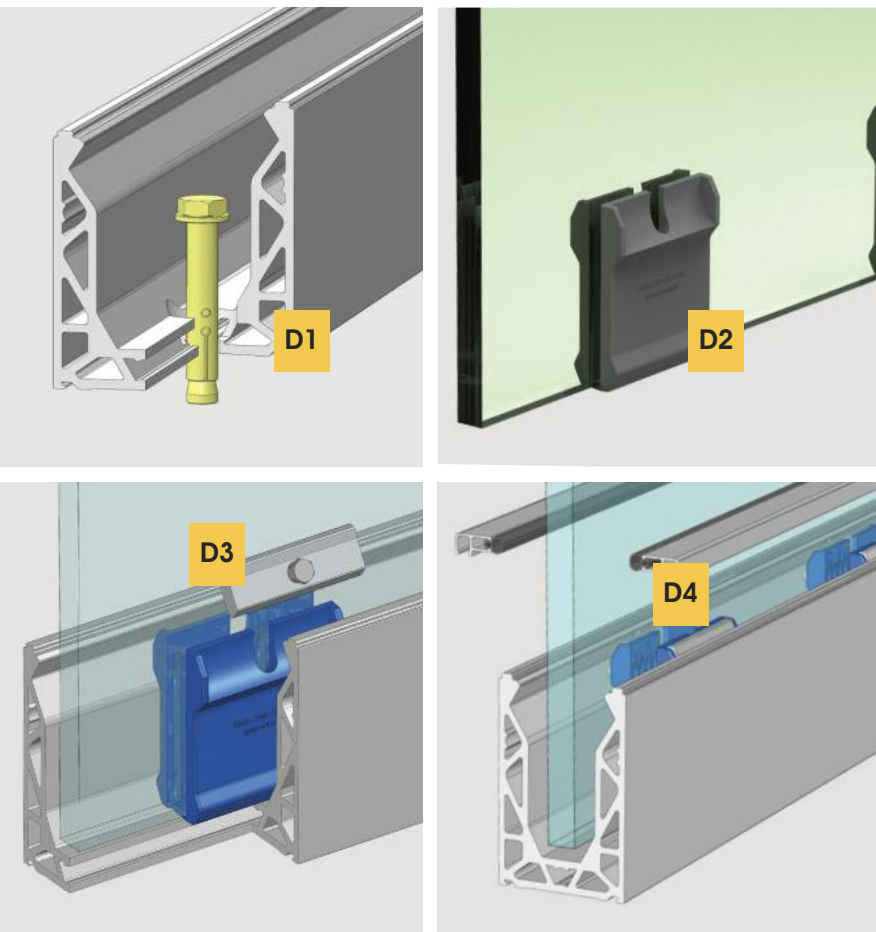

## Posiglaze is so easy to install

- 1** Fit the base channel (D1) to the substructure (Details on suitable fixing can be found on our website).
- 2** Clip the glass slip clamps (D2) to the bottom edge of the glass panel (We produce different sized clamps for different glass thicknesses).
- 3** Place the bolt screws in the pivot clamp (D3).
- 4** Position the glass in the channel.
- 5** Using the adjustment bolts; loosening one side and tightening the other. This will allow the alignment of the glass with the next panel and enable vertical alignment of the glass.
- 6** Attaching the cover strip (D4) and bead gasket.

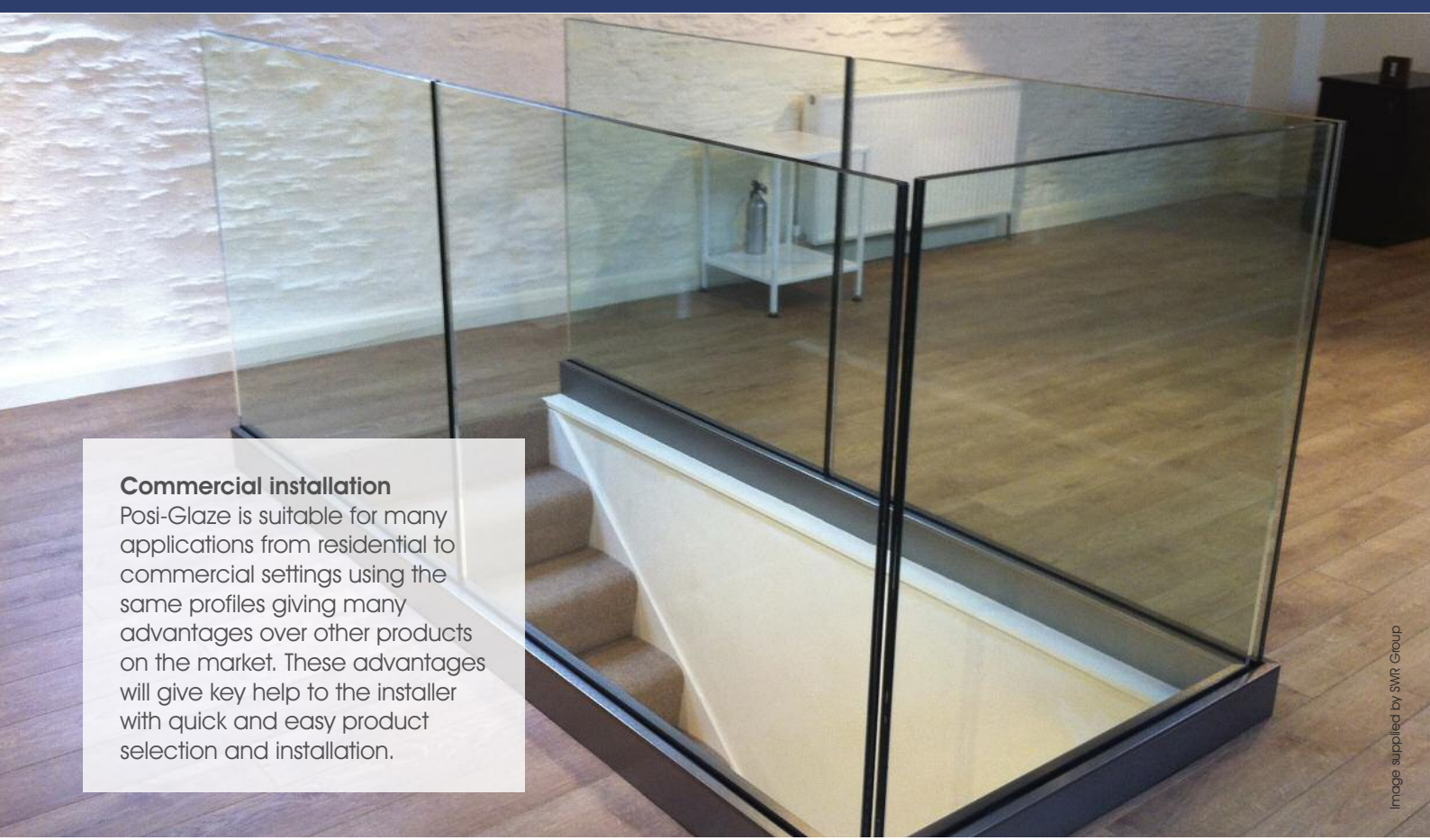

Image supplied by SWR Group

**Commercial installation**

Posi-Glaze is suitable for many applications from residential to commercial settings using the same profiles giving many advantages over other products on the market. These advantages will give key help to the installer with quick and easy product selection and installation.



**3 metre of base drilled kit** CODE POSIBASE3000  
 ALSO AVAILABLE IN 6 METER. PLEASE CONTACT US FOR DETAILS.

- POSIGLAZE BASE DRILLED KIT COMPRISES OF:**
- 1 x 3m Base Drilled Channel
  - 2 x 3m Top Clip Bead
  - 1 x Clamp kit to suit specified glass thickness
  - 1 x Spanner



**3 metre of side drilled kit** CODE POSISIDE3000  
 ALSO AVAILABLE IN 6 METER. PLEASE CONTACT US FOR DETAILS.

- POSIGLAZE SIDE DRILLED KIT COMPRISES OF:**
- 1 x 3m Side Drilled Channel
  - 1 x 3m Top Clip Bead
  - 1 x 3m Side Cladding
  - 1 x Clamp kit to suit specified glass thickness
  - 1 x Spanner

## POSI-GLAZE PARTS AND ACCESORIES

PRODUCT	CODE	PRODUCT DESCRIPTION
---------	------	---------------------



**Base Drilled Posi-Glaze**

3m S/S Brushed      PGC-010  
3m Natural Anodised      PGC-010C

Base Drilled Posi-Glaze channel. This is the main section that hold the glass. It is predrilled at 100mm from the ends and then 200mm there after. The hole is to suit a 12mm fixing bolt and is counter bored to sink the bolt head. Natural anodised channel is a matt silver finish used when the channel is below floor level, such as with decking or tiling when the channel is in line with the finished floor level.



**Side Drilled Posi-Glaze**

3m Natural Anodised      PGC-020

Sided Drilled Posi-Glaze channel. This is the main section that hold the glass. It is predrilled at 100mm from the ends and then 200mm thereafter. The hole is to suit a 12mm fixing bolt and is counter bored to sink the bolt head. Drilled through both walls, one side to allow socket through.



**90° Corner**

S/S Brushed      PGA-090

A Pre-fabricated 90° corner. Supplied with four dowels for easier fitting. Does not include extra top seal strip or side cladding.

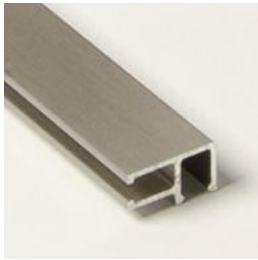

**Top Seal Strip**

3m S/S Brushed      PGA-030

The top seal strip holds the gasket and is pressed onto the channel at the end of the installation. Covers the clamps from and prevents debris from entering the channel.



**Bottom Cladding**

3m S/S Brushed      PGA-020

To be used with side fixed channel if required, gives an angled finish to the bottom of the channel. Clips into the grooves under the channel, will require adhesive for securing in place.



**Side Cladding**

3m S/S Brushed      PGA-010

As with the top seal strip it holds the gasket in place and covers the clamps from view. To be used with side drilled channel to cover the drill holes from view. Requires adhesive to hold flat surface against channel. Also used with natural anodised channel to give stainless steel finish.

## PRODUCT

## CODE

## PRODUCT DESCRIPTION



### Clamp Kits

(Inc. Clamps, gasket, bars, bolts)

12mm Glass	PGB-0012
13.5mm Glass	PGB-0013
15mm Glass	PGB-0015
17.5mm Glass	PGB-0017
19mm Glass	PGB-0019
21.5mm Glass	PGB-0021

Clamp kits have enough components to suit a 3m length of channel. The clamps can fit glass thicknesses 1mm either way of said glass thickness i.e. 15mm glass clamps will suit 14 - 16mm glass. Included are the clamp bars, which sit into the top mould of the clamps and the clamp bolts, which screw into the bars and are then undone to hold the glass in place. These are undone and tightened each side allowing the glass alignment. 6m gasket to suit glass thickness.



### Gasket

1m Large Gasket	PGA-001
1m Small Gasket	PGA-002

Extra gasket can be supplied in any length. The small gasket suits 19 - 21mm glass, the large gasket suits 12 - 17.5mm glass.



### End Caps

End Cap Base Drilled	PGA-060
End Cap One Side-Clad	PGA-061
End Cap Two Side-Clad	PGA-062
End Cap Shaped Right	PGA-065R
End Cap Shaped Left	PGA-065L
End Cap Knock-in Base Drilled	PGA-060R

Stainless steel end caps cut to suit each option. An adhesive will need to be used to hold them in place.



### Dowel

PGA-070

The dowels are used to allow for better alligning when joining channel sections together. There are three slots in the channel to hold dowels although two would be enough.



### Spanner

PGA-050

Steel spanner with angle to reach the clamp bolts to tighten/loosen the glass.



### Drain Block

PV08DB  
PV08DBSIDE

Anodised aluminium drain block. Fitted between the substrate and channel behind each hole to allow water to escape.

## PROFILE DIMENSIONS

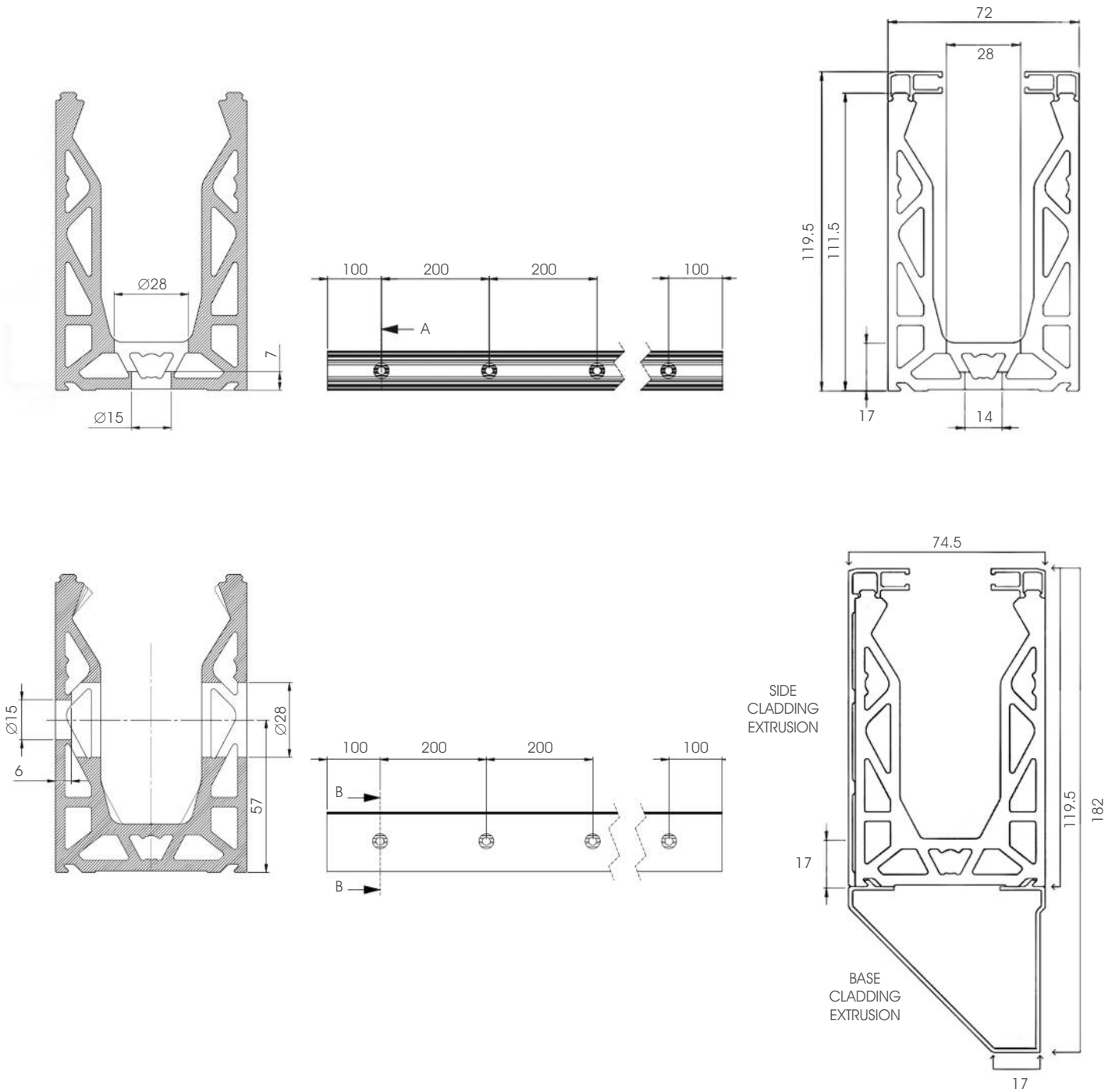



## FITTING APPLICATIONS



### BSI with 6180:2011

Meets BSI standard 6180:2011. We've designed Posiglaze to meet BSi 6180:2011, 1.5kN loading. Visit our website for a dedicated guide to what glass thickness should be used and further fitting instructions.

Please note these are only fitting suggestions, Posiglaze should always be fitted to a suitable sub structure, if in doubt contact a qualified professional.



Our PosiGlaze channel has passed the CSTB 5 test. This was completed by our French/Italian distributor Logli Massimo under their product name DEFENDER 450.

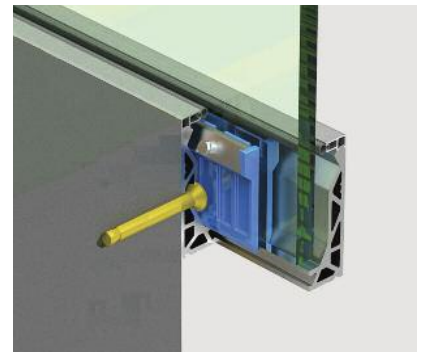
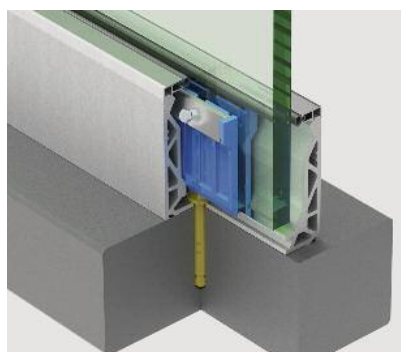
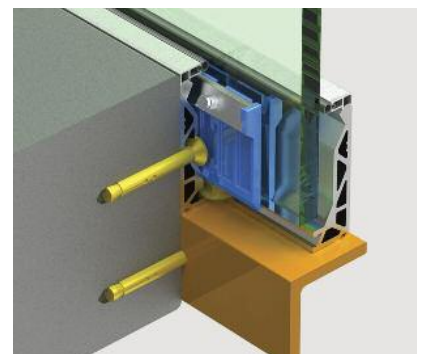
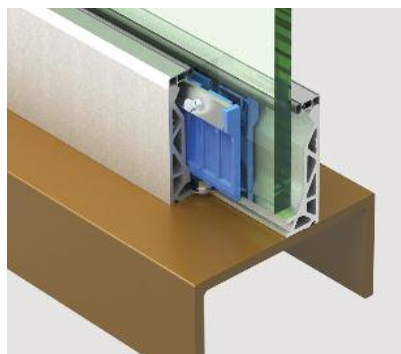
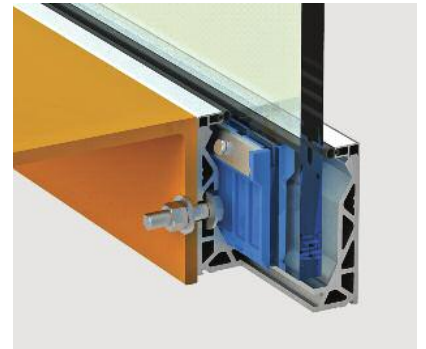
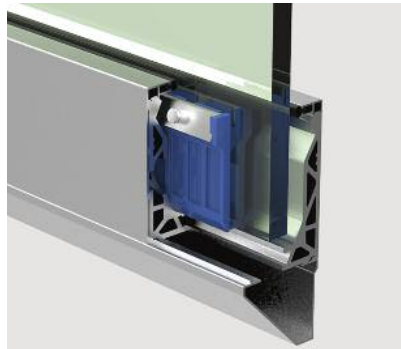



**Melbourne Office**

170 Derrimut Drive Derrimut Vic 3030

**Adelaide Office**

7 Manfull St. Melrose Park SA 5039

**T:** 1300 4 ELITE

**E:** [sales@eliteglassolutions.com.au](mailto:sales@eliteglassolutions.com.au)

[www.eliteglassolutions.com.au](http://www.eliteglassolutions.com.au)